

OCS-SL series crane scale



Multi-weighing units:

Kg, lb, N are selectable, generally kg is the default unit.

Multi-function operation:

Tare ; Zero ; Auto zero tracking ; Total ; Hold; Overload warning and record, operate through remote controller ,etc functions.

User-friendly design:

Cast aluminium housing for maximum protection; Large red 5 digit LED display (digit height 30mm); Battery Operated with low battery indication; Automatic turn off , power-saving function.

Standard	According to OIML class III			
Display	30mm (1.2") 5digits LCD/LED			
Zero Range	4% F.S.			
Tare Range	100% F.S.			
Stable Time	≤10seconds			
Overload Indication	100% F.S. + 9e			
Max. Safety Load	125% F.S.			
Ultimate Load	400% F.S.			
Battery Life	≥50 hours			
Battery Type	Fully sealed Lead-Acid battery, 6V/4.5Ah			
Adapter	DC9V/1000mA			
Operating Humidity	≤85% RH under 20°C			
Remote Controller Distance	Min. 15m			
Battery of Remote Controller	AAA battery, 1.5V×2			
MODEL	Max. capacity(kg)	Min. weigh(kg)	Division(kg)	Total display counts(n)
OCS-2 -SL	2000	20	1	2000
OCS-3-SL	3000	20	1	3000
OCS-5-SL	5000	40	2	2500
OCS-10-SL	10000	100	5	3000
OCS-15-SL	15000	200	5	3000
OCS-20-SL	20000	200	10	2000

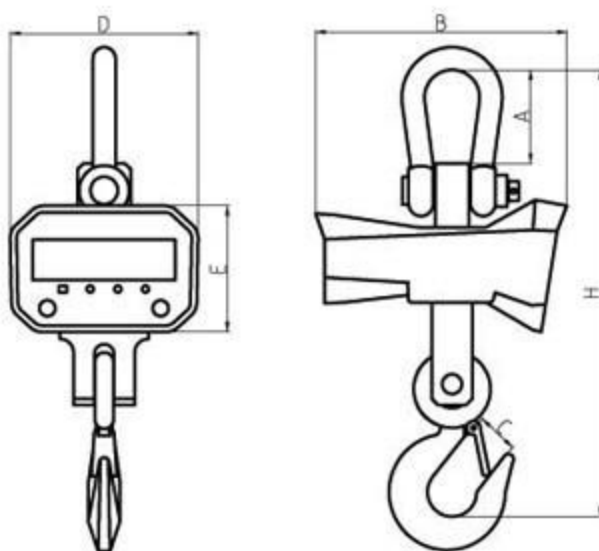

MODEL	A(mm)	B(mm)	C(mm)	D(mm)	E(mm)	H(mm)	N.W (kg)
OCS-2 -SL	95	260	33	195	135	430	10,50
OCS-3-SL	95	260	40	195	135	455	11,50
OCS-5-SL	120	325	50	240	165	535	17,50
OCS-10-SL	124	325	60	240	165	660	27,50
OCS-15-SL	225	345	70	240	165	855	49,00
OCS-20-SL	225	345	85	240	165	920	56,00