

HP series Crane Scale

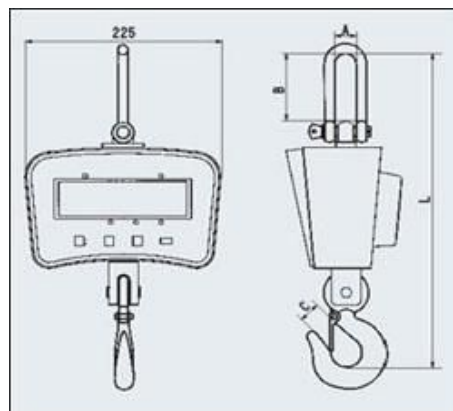

- *. 38mm LED display
- *. Gross/Net weight display convertible
- *. Multi-functions: Tare; Zero; Hold; Overload warning
- *. Weight accumulation function
- *. Auto shut off
- *. Remote control calibration
- *. Infrared remote control distance:10m
- *. Kg/lb units
- *. Die-casting aluminum housing
- *. High duty stainless shackle and eye hook
- *. Gravity acceleration set - option
- *. Acid-lead rechargeable battery 6V/5Ah
- *. Anti-magnetic & water-proof



- *. Weight accuracy: OIML III standard.
- *. Continuous working: 100 hours(LCD);60 hours(LED)
- *. Safe overload: 120%F.S.
- *. Operating temp: - 10°C ~ + 40°C
- *. Operating humidity: <= 90%R.H.

Model	Capacity	Division	N.W. (kg)	L(mm)	A(mm)	B(mm)	C(mm)
OCS-M 0.3t	0.1kg	4	335	20	80	20	
OCS-M 0.5t	0.2kg	4.5	370	20	85	30	

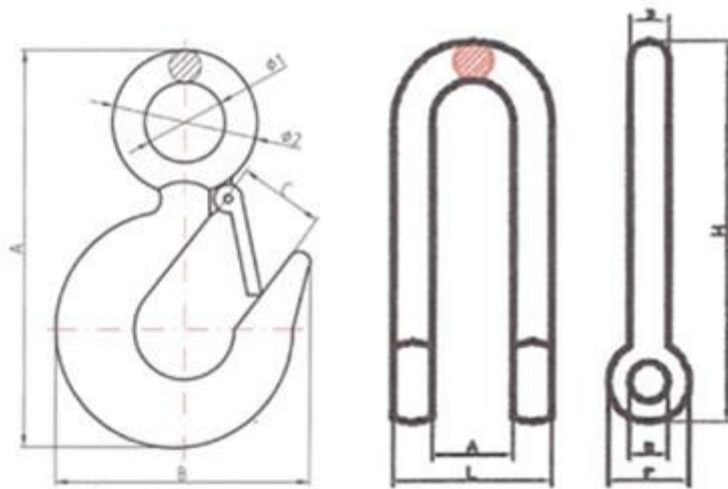

Scale	WILL	BL	Dimension(mm)						Weight
			A	B	D	H	L	F	
0.3t	1t	4t	20	10	10	98	39	20	0.2kg
0.5t	1 1/2t	6t	25	12	12	118	49	25	0.3kg

Hook

Scale	WILL	BL	Dimension(mm)					φ1	φ2	Weight
			A	B	C					
0.3t	1t	4t	110	66	28		18	37	0.26kg	
0.5t	1.5t	6t	125	75	28		23	44	0.38kg	